

65039

**HIGH RELIABILITY HALL EFFECT STUD,
NON-LATCHING OUTPUT WITH CABLE**



09/05/06

Features:

- Wide operating temperature range -55 °C to +150°C
- High magnetic sensitivity
- Wide operating voltage range 18 to 32 V
- Chopper stabilized amplifier minimizes amplifier offset resulting in improved temperature stability
- MIL-STD-202 and MIL-STD-461E Qualified

Applications:

- Proximity sensing
- Gear tooth sensing
- Speed sensing
- Angular Position sensing

DESCRIPTION

The 65039 Hall effect stud sensor switches when exposed to the minimum specified magnetic field level. The sensor switches LOW when sensing the minimum required magnetic field and switches HIGH when the magnetic field is removed. The sensor is built into a threaded stainless steel tube and contains a single element Hall effect IC. Additional circuitry is added to expand the operating supply voltage range and provide surge protection against outside induced transients.

ABSOLUTE MAXIMUM RATINGS

Supply Voltage Range.....	18.0 V to 32.0 V
Input Supply Current	25 mA
Power Dissipation, @ T _A = 25°C (P _D).....	100 mW
Output Current	20 mA
Storage Temperature.....	-65°C to +150°C
Operating Free-Air Temperature Range.....	-55°C to +150°C

Package Dimensions

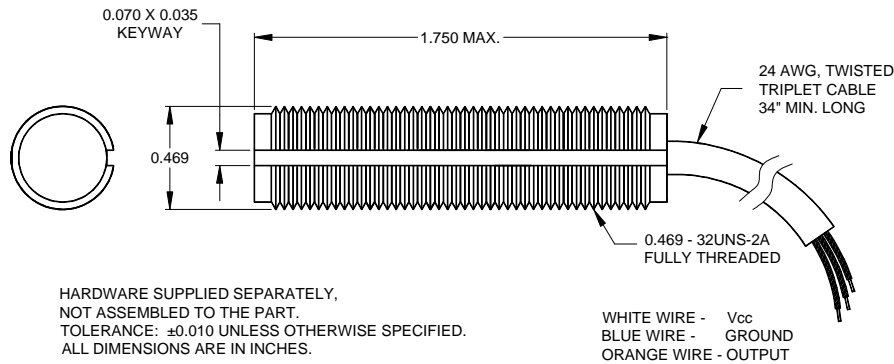

Schematic Diagram

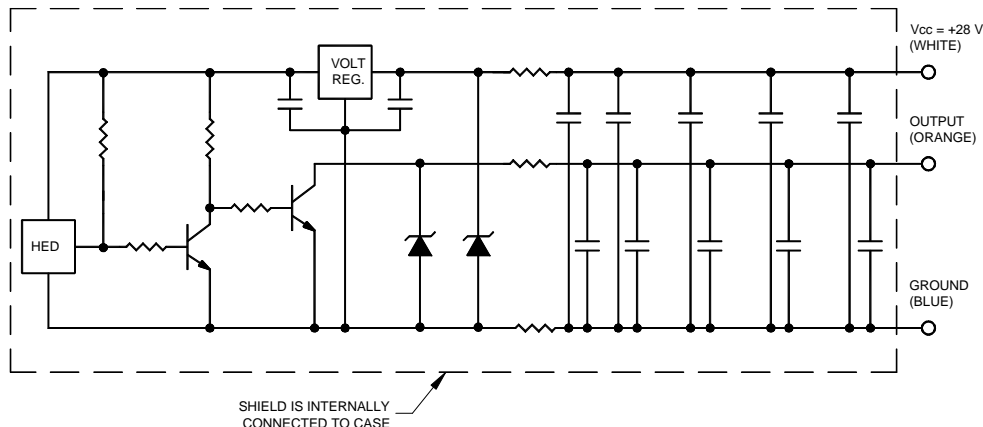

65039

HIGH RELIABILITY HALL EFFECT STUD, NON-LATCHING OUTPUT WITH CABLE

09/05/06

ELECTRICAL CHARACTERISTICS

T_A = 25°C unless otherwise specified.

PARAMETER	SYMBOL	MIN	TYP	MAX	UNITS	TEST CONDITIONS
Supply Voltage	V _{CC}	18.0		32.0	V	Continuous Operating
Supply Current	I _{CC}			25	mA	V _{CC} = 28.0 V
Output Saturation Voltage	V _{OL}			1.0	V	V _{CC} = 28 V, I _{OL} = 20 mA, B = 250 G
Output Leakage Current	I _{OH}			100	μA	V _{CC} = 28 V, B = 0 G, Output High
Power on Response Time	t _{ON}			20	ms	V _{CC} > 18 V

MAGNETIC CHARACTERISTICS

T_A = 25°C

PARAMETER	SYMBOL	MIN	TYP	MAX	UNITS	TEST CONDITIONS
Magnetic Operate Point	B _{OP}			200	G	V _{CC} = 28 V, I _{OL} = 20 mA
Magnetic Release Point	B _{RP}	60			G	V _{CC} = 28 V, I _{OL} = 20 mA
Polarity	P		Low High			B > B _{OP} B < B _{RP}

Qualified to the following requirements:

Environmental

- MIL-STD-202 METHOD 105C Altitude, Test Condition B
- MIL-STD-202 METHOD 214A Random Vibration, 3 Hrs/Axis
- 3 Impact Shocks, 6 Orthogonal Axis Mechanical Shock, 20 G's for 11 seconds
- MIL-STD-202 METHOD 103B Humidity, Condition B, 96 Hours
- MIL-STD-202 METHOD 109C Explosive Atmosphere
- MIL-STD-202 METHOD 110A Sand and Dust
- ASTM G85.A4 Salt Spray, SO₂, 336 Hours
- MIL-STD-202 METHOD 112 Helium Leak Test, < 1 X 10⁻⁶ Torr, Condition D
- MIL-STD-202 METHOD 107G Thermal Shock, -65°C to +125°C

EMI / EMC

- MIL-STD-461E RS103 Radiated Susceptability, 200 V/m (30 MHz to 18 GHz)
- MIL-STD-461E CS114 Conducted Susceptability, Limit Curve 5
- MIL-STD-461E CS115 Conducted Susceptability, I_{MAX} 5 A
- MIL-STD-461E CS116 Conducted Susceptability, I_{MAX} 10 A

Lightning Strike

- RTCA DO-160 Section 22, Waveform A Induced Indirect Differential Transient, 70 V or 5 A

ORDERING INFORMATION:

PART NUMBER	DESCRIPTION
65039-001	Commercial
65039-101	Screened